

ECW5210-L

Indoor Access Point

Concurrent Dual-Band 11ac indoor AP



Product Overview

The ECW5210-L is an enterprise-grade, concurrent dual-band 802.11ac indoor access point, designed specifically for high-density environments such as offices, universities, hotels, and hospitals. Featuring two 3x3 MIMO radios that can support up to 450 Mbps and 1300 Mbps data rates in the 2.4 and 5 GHz bands respectively, the ECW5210-L is ideal for providing wire-like performance that is crucial for businesses. Traffic prioritization ensures that bandwidth-hungry applications such as 4K videos can stream perfectly, while enforcing strict quality of service requirements for VoIP and mission-critical services.

Given the overcrowding of the 2.4 GHz band by legacy Wi-Fi devices, more and more devices and networks are migrating to the 5 GHz band for increased performance. The wider channels and additional spatial streams offered by 802.11ac allows the ECW5210-L to meet high-capacity demands while providing three-fold performance over 802.11n networks. However, due to the significant proportion of 2.4 GHz-only clients in use today, the ECW5210-L's ability to service clients in both the 2.4 GHz and 5 GHz bands becomes essential for organizations that want to improve overall wireless experience without sacrificing legacy support.

The ECW5210-L's exterior is composed of a UL94-5VB-rated, pearl-white plastic front panel and a metallic back plate – a simplistic and elegant design that is perfect for blending into everyday public or working environments. Furthermore, the camouflaged appearance of the ECW5210-L is accentuated by its six internal antennas, which serve to amplify wireless coverage. With two different mounting mechanisms, the ECW5210-L can be easily mounted on walls or ceilings. Combined with PoE (Power over Ethernet) support that eliminates the need for traditional power sources, the ECW5210-L offers unparalleled deployment flexibility.

When used with an Edgecore Controller, the ECW5210-L supports a wide-array of value-added applications required by enterprises and organizations, such as bandwidth control, user authentication and billing, centralized WLAN management, and much more. Along with stringent yet customizable security policies, the flexible and fully-featured ECW5210-L becomes the ideal choice for all types of businesses, from small coffee shops to large corporations.

Highlights

- Concurrent dual-band 2.4 GHz and 5 GHz
- 802.11ac 3x3 MIMO supporting up to 1300 Mbps data rate
- Ceiling-mountable UL94-5VB fire-retardant plastic housing
- 802.3at Power over Ethernet (PoE) compatible
- Standalone or centrally managed by an Edgecore controller
- Integrated enterprise-grade, standards-based security
- Up to 16 ESSIDs per radio with 802.1Q VLAN
- Captive portal and guest provisioning^{*1}
- Rogue AP detection & Load balancing^{*1}
- Fast Layer 2/Layer 3 roaming^{*1}

^{*1}: When used in conjunction with an Edgecore controller

Features

Very High Throughput

The demand for 802.11ac is growing tremendously as enterprises and organizations seek to increase bandwidth and alleviate network congestion. With wider channel widths, an increased number of supported spatial streams, and more advanced modulation techniques, the 11ac-enabled ECW5210-L provides data rates significantly higher than that of 802.11n access points. Furthermore, each device can transmit the same amount of data in a much shorter period of time, improving overall network capacity and performance while ensuring smooth operation of sensitive network applications.

Ready for High-Density Environments

With the ability to operate in the 2.4 and 5 GHz bands, the ECW5210-L can distribute clients on separate channels, thereby mitigating channel congestion. The ECW5210-L also implements advanced AP features such as airtime fairness, multicast to unicast conversion, and optimal client filtering, improving wireless performance in high-density environments while ensuring uninterrupted access to mission-critical resources and delay-sensitive applications. Wireless QoS with standards-based 802.11e/WMM (Wi-Fi Multimedia) further guarantees a wire-like experience.

Maximum Deployment Flexibility

Supporting 802.3at PoE, the ECW5210-L can be placed in locations where traditional power sources are unavailable, such as high ceilings and walls. In addition, its plenum-rated materials allows it to be placed in ceiling areas safely without having to worry about being a fire hazard, further increasing deployment flexibility.

Enterprise-grade, Standards-based Security

With 802.1X authentication and a backend RADIUS server, the ECW5210-L can prevent unauthorized users from accessing the corporate intranet. Furthermore, the AP's Layer 2 firewall capability blocks unwanted traffic, reducing network overhead and providing an added layer of security. Finally, the AP can be configured with multiple SSIDs, each utilizing different security standards (e.g. WPA2-Enterprise) and VLAN tags, which enables easy network segmentation to protect corporate resources.

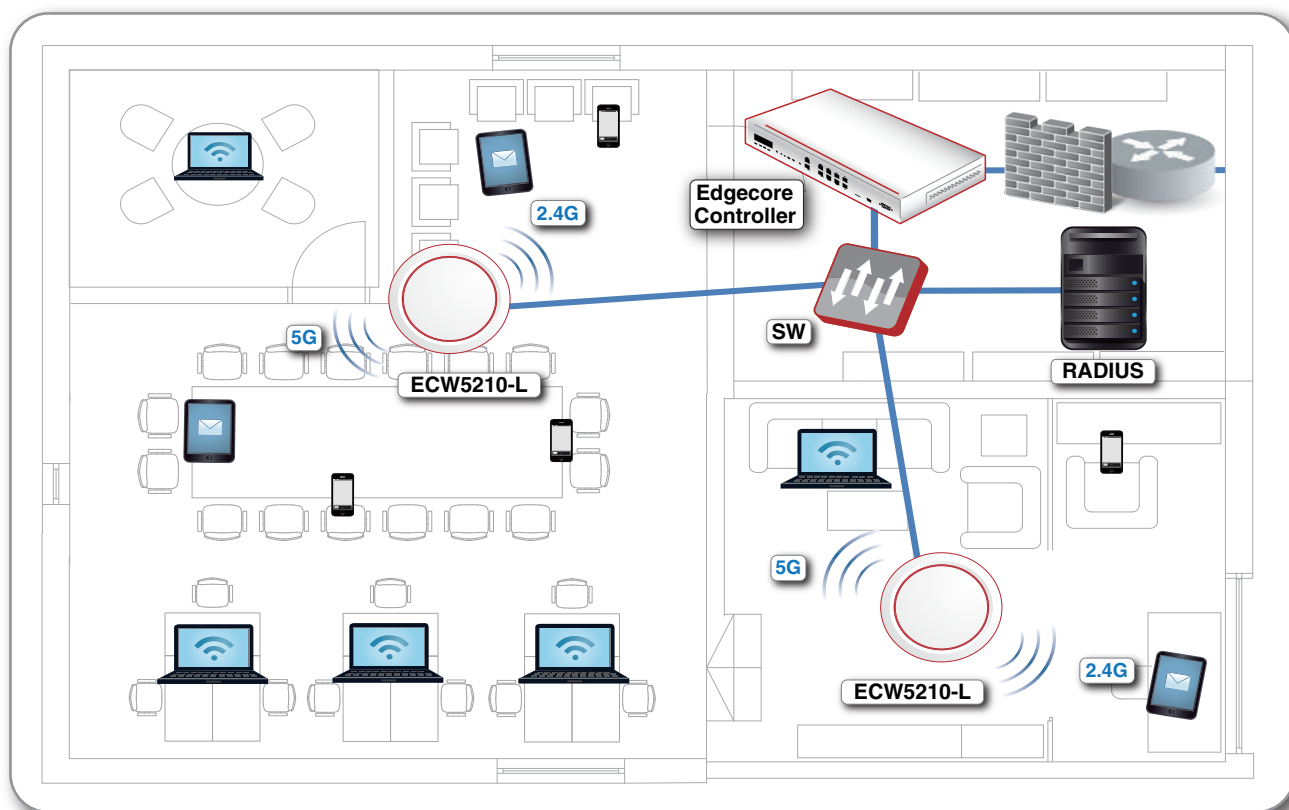

Features

Physical

- Power:
- DC Input: 12 V/2.5 A (power adapter optional)
 - PoE: 802.3at compliant (PoE injector optional)
- Dimensions: 18.0 cm (L) x 18.0 cm (W) x 4.4 cm (H)
- Weight: 0.61 kg (1.35 lb)
- Interfaces:
- Uplink: 1 x 10/100/1000BASE-T Ethernet, Auto MDIX, RJ-45 with 802.3at PoE
- LED Indicator: Uplink
- Environmental Conditions:
- Operating Temperature: -10°C (14°F) to 40°C (104°F)
 - Operating Humidity: 10% to 90% non-condensing
 - UL94-5VB Rating
- Power Consumption: 17.0 W max.
- Antenna:
- Type: 6 x built-in PIFA (3 x 2.4 GHz and 3 x 5 GHz)
 - Gain: 3 dBi (2.4 GHz), 5 dBi (5 GHz)
- Mounting:
- Wall mount (mounting panel included)
 - Ceiling mount (ceiling mount kit included)

Wi-Fi

- Standards:
- 802.11a/b/g/n/ac
- Concurrent dual-band 2.4 GHz and 5 GHz
- Supported Data Rates:
- 802.11b: 1, 2, 5.5, 11 Mbps
 - 802.11a/g: 6, 9, 12, 18, 24, 36, 48, 54 Mbps
 - 802.11n: 6.5 – 216.7 Mbps (20 MHz)
 - 802.11n: 13.5 – 450 Mbps (40 MHz)
 - 802.11ac: 6.5 – 260.1 Mbps (20 MHz)
 - 802.11ac: 13.5 – 600 Mbps (40 MHz)
 - 802.11ac: 29.3 – 1300 Mbps (80 MHz)
- Radio Chains: 3 x 3
- Spatial Streams: 3
- Output Power:
- 2.4 GHz: Up to 25 dBm*1
 - 5 GHz: Up to 25 dBm*1
- Channelization: 20 MHz, 40 MHz, 80 MHz
- Frequency Band: 2.412 – 2.472 GHz, 5.180 – 5.825 GHz
- Operating Channels:
- 2.4 GHz: 1 – 11 (US), 1 – 13 (Europe), 1 – 13 (Japan)
 - 5 GHz*2: 36 – 165 (US), 36 – 140 (Europe), 36 – 140 (Japan)
- ESSIDs: Up to 16 per radio (32 total)
- Certifications: FCC (United States), CE (Europe), NCC (Taiwan)

Performance

- Physical Data Rate:
- Up to 450 Mbps (2.4 GHz)
 - Up to 1.3 Gbps (5 GHz)
- Concurrent Users: Up to 384 (256 on 2.4 GHz, 128 on 5 GHz)

Quality of Service

- Wireless QoS (802.11e/WMM)
- DSCP (802.1p)
- Airtime fairness
- Band steering
- Multicast to unicast conversion
- Optimal client filtering

*1: Maximum power is limited by local regulatory requirements
 *2: Some channels are restricted by local regulatory requirements

Management

- Deployment:
- Standalone
 - Tunneled management by controller
 - IPv4 and IPv6 compatible
- Configuration:
- Web user interface (HTTP/HTTPS)
 - SNMP v1, v2c, v3

Security

- Wireless Security:
- WEP
 - WPA/WPA2 Mixed
 - WPA2-Personal
 - WPA2-Enterprise (802.1X)
 - TKIP and AES Encryption
- VLAN tagging (802.1Q)
- Station isolation
- DHCP snooping
- Layer-2 firewall

Mobility/Roaming

- 802.1X Preauthentication
- Layer 2/Layer 3 fast roaming

Receive Sensitivity

Operating Mode	Data Rate	Receive Sensitivity (dBm)
802.11b	1 Mbps	-95
	11 Mbps	-90
802.11a	6 Mbps	-95
	54 Mbps	-81
802.11g	6 Mbps	-95
	54 Mbps	-81
802.11n (HT20)	MCS0	-95
	MCS7	-77
	MCS8	-93
	MCS15	-73
802.11n (HT40)	MCS0	-91
	MCS7	-74
	MCS8	-89
802.11ac (VHT20)	MCS0	-83
	MCS8	-60
	MCS15	-70
802.11ac (VHT40)	MCS0	-80
	MCS9	-55
802.11ac (VHT80)	MCS0	-77
	MCS9	-52

Features

Warranty

Please check www.edge-core.com for the warranty terms in your country.

For More Information

To find out more about Edgecore Networks Corporation products and solutions, visit www.edge-core.com.

About Edgecore Networks Corporation

Edgecore Networks Corporation is in the business of providing innovative network solutions. In the service provider network, in the data center or in the cloud, Edgecore Networks Corporation delivers the software and systems that transform the way the world connects. Edgecore Networks Corporation serves customers and partners worldwide. Additional information can be found at www.edge-core.com.

Edgecore Networks Corporation is a subsidiary of Accton Technology Corporation, the leading network ODM company. The Edgecore data center switches are developed and manufactured by Accton.

To purchase Edgecore Networks solutions, please contact your Edgecore Networks Corporation representatives at +886 3 563 8888 (HQ) or +1 (949)-336-6801 or authorized resellers.

© Copyright 2018 Edgecore Networks Corporation. The information contained herein is subject to change without notice. This document is for informational purposes only and does not set forth any warranty, expressed or implied, concerning any equipment, equipment feature, or service offered by Edgecore Networks Corporation. Edgecore Networks Corporation shall not be liable for technical or editorial errors or omissions contained herein.