

Product Specification

10km 100G eCWDM4 QSFP28 Optical Transceiver Module (4WDM-10)

FTLC1155RGPLD

PRODUCT FEATURES

- Hot-pluggable QSFP28 form factor
- Supports 103.1Gb/s aggregate bit rate
- Power dissipation < 4.5W
- RoHS-6 compliant
- Industrial case temperature range of -40°C to +85°C
- Adaptive CTLE
- Single 3.3V power supply
- Maximum link length of 10km on Single Mode Fiber (SMF) [with KR4 FEC]
- 4x25Gb/s CWDM transmitter
- 4x25G retimed electrical interface
- Duplex LC receptacles
- I2C management interface



APPLICATIONS

- 100G 4WDM applications with FEC
- Outside plant
- Reduced air flow central office

Finisar's FTLC1155RGPLD QSFP28 transceiver modules are designed for use in 100 Gigabit Ethernet links on up to 10 km of single mode fiber (CWDM4 wavelength grid). Designed for outside plant applications with an industrial temperature range (-40°C to +85°C), they are compliant with the QSFP28 MSA¹, CWDM4 MSA², 4WDM MSA³, and portions of IEEE P802.3bm CAUI-4⁴. Digital diagnostic functions are available via the I2C interface, as specified by the QSFP28 MSA and Finisar Application Notes AN-2153⁵ and AN-2154⁶. The optical transceiver is compliant per the RoHS-6 Directive 2011/65/EU⁷. See Finisar Application Note AN-2038⁸ for more details.

PRODUCT SELECTION

FTLC1155RGPLD

- 5: Gen 2
- R: Ethernet maximum bit rate (103.1 Gb/s)
- G: 4x25G CWDM optical architecture
- P: Pull-tab release
- L: LC straight receptacles
- D: Extended reach (10 km), industrial temperature range

I. Pin Descriptions

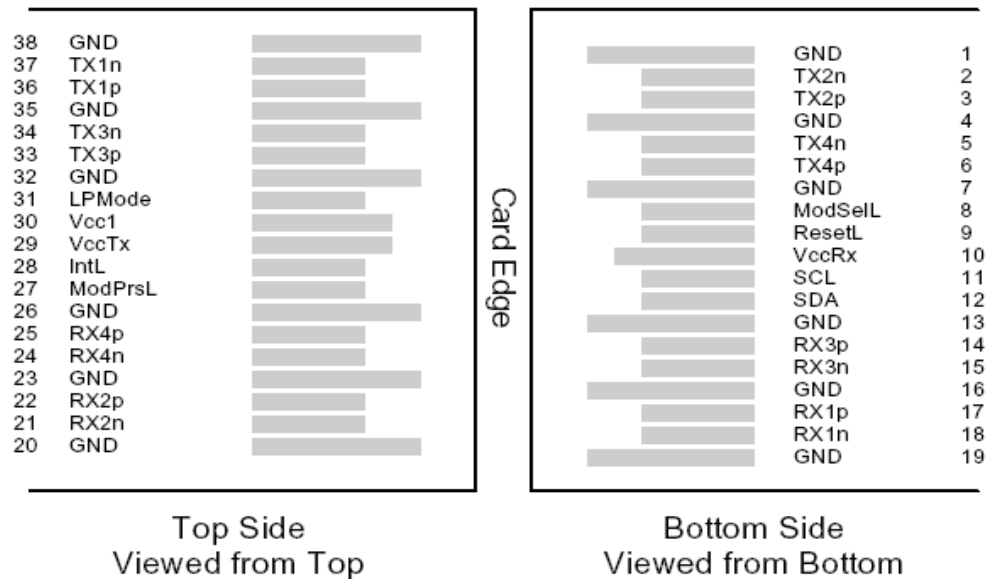

Figure 1 – QSFP28-compliant 38-pin connector (per SFF-8679)

Pin	Symbol	Name/Description	Notes
1	GND	Ground	1
2	Tx2n	Transmitter Inverted Data Input	
3	Tx2p	Transmitter Non-Inverted Data Input	
4	GND	Ground	1
5	Tx4n	Transmitter Inverted Data Input	
6	Tx4p	Transmitter Non-Inverted Data Input	
7	GND	Ground	1
8	ModSelL	Module Select	
9	ResetL	Module Reset	
10	Vcc Rx	+3.3 V Power supply receiver	
11	SCL	2-wire serial interface clock	
12	SDA	2-wire serial interface data	
13	GND	Ground	1
14	Rx3p	Receiver Non-Inverted Data Output	
15	Rx3n	Receiver Inverted Data Output	
16	GND	Ground	1
17	Rx1p	Receiver Non-Inverted Data Output	
18	Rx1n	Receiver Inverted Data Output	
19	GND	Ground	1
20	GND	Ground	1
21	Rx2n	Receiver Inverted Data Output	
22	Rx2p	Receiver Non-Inverted Data Output	
23	GND	Ground	1
24	Rx4n	Receiver Inverted Data Output	
25	Rx4p	Receiver Non-Inverted Data Output	
26	GND	Ground	1
27	ModPrsL	Module Present	
28	IntL	Interrupt	
29	Vcc Tx	+3.3 V Power supply transmitter	
30	Vcc1	+3.3 V Power Supply	

31	LPMODE	Low Power Mode	
32	GND	Ground	1
33	Tx3p	Transmitter Non-Inverted Data Input	
34	Tx3n	Transmitter Inverted Data Input	
35	GND	Ground	1
36	Tx1p	Transmitter Non-Inverted Data Input	
37	Tx1n	Transmitter Inverted Data Input	
38	GND	Ground	1

Notes

1. Circuit ground is internally isolated from chassis ground.

II. Absolute Maximum Ratings

Module performance is not guaranteed beyond the operating range (see Section VI). Exceeding the limits below may damage the transceiver module permanently.

Parameter	Symbol	Min	Typ	Max	Unit	Ref.
Maximum Supply Voltage	V _{CC}	-0.5		3.6	V	
Storage Temperature	T _S	-40		+85	°C	
Case Operating Temperature	T _{OP}	-40		+85	°C	
Relative Humidity	RH	15		85	%	1
Receiver Damage Threshold, per Lane	P _{Rdmg}	3.5			dBm	

Notes:

1. Non-condensing.

III. Electrical Characteristics (EOL, T_{OP} = -40 to +85 °C, V_{CC} = 3.135 to 3.465 Volts)

Parameter	Symbol	Min	Typ	Max	Unit	Ref.
Supply Voltage	V _{CC}	3.135		3.465	V	
Supply Current	I _{CC}			1.6	A	
Module total power	P			4.5	W	1
Transmitter						
Signaling rate per lane		25.78125 ± 100 ppm			GBd	
Differential data input swing per lane	V _{in,pp}			900	mV	
Differential input return loss (min)	RL _d (f)	9.5 – 0.37f, 0.01 ≤ f < 8 4.75 – 7.4log ₁₀ (f/14), 8 ≤ f < 19			dB	
Differential to common mode input return loss (min)	RL _{dc} (f)	22-20(f/25.78), 0.01 ≤ f < 12.89 15-6(f/25.78), 12.89 ≤ f < 19			dB	
Differential termination mismatch				10	%	
Stressed input parameters						
Eye width			0.46		UI	
Applied pk-pk sinusoidal jitter		Per IEEE 802.3bm Table 88-13				
Eye height			95		mV	
DC common mode voltage		-350		2850	mV	
Receiver						
Signaling rate per lane		25.78125 ± 100 ppm			GBd	
Differential data output swing	V _{out,pp}	100		400	mVpp	2
		300		600		
		400		800		
		600		1200		
Eye width		0.57			UI	
Vertical eye closure				5.5	dB	

Differential output return loss (min)	RLd(f)	9.5 – 0.37f, 0.01 ≤ f < 8 4.75 – 7.41log ₁₀ (f/14), 8 ≤ f < 19		dB	
Common to differential mode conversion return loss (min)	RLdc(f)	22-20(f/25.78), 0.01 ≤ f < 12.89 15-6(f/25.78), 12.89 ≤ f < 19		dB	
Differential termination mismatch				10	%
Transition time, 20% to 80%	t _r , t _f	12			ps

Notes:

- Maximum total power value is specified across the full temperature and voltage range. Power consumption ≤ 4.5W when stabilized (both Tx and Rx CDR locked), but may be ≤ 5W during locking acquisition.
- Output voltage is settable in 4 discrete ranges via I2C. Default range is Range 2 (400 – 800 mV).

IV. Optical Characteristics (EOL, T_{OP} = -40 to +85 °C, V_{CC} = 3.135 to 3.465 Volts)

Parameter	Symbol	Min	Typ	Max	Unit	Ref.
Transmitter						
Signaling Speed per Lane		25.78125 ± 100 ppm			GBd	1
Lane center wavelengths (range)		1264.5 – 1277.5 1284.5 – 1297.5 1304.5 – 1317.5 1324.5 – 1337.5			nm	
Transmit OMA per Lane	TxOMA1	-4		2.5	dBm	
Transmit OMA per Lane @TDP max	TxOMA2	-2			dBm	2
Transmit Average Power per Lane				2.5	dBm	8
Optical Extinction Ratio	ER	3.5			dB	
Transmitter and Dispersion Penalty per Lane	TDP			3	dB	3
Launch Power (OMA-TDP)	OMA-TDP	-5			dBm	
Sidemode Suppression ratio	SSR _{min}	30			dB	
Average launch power of OFF transmitter, per lane				-30	dBm	
Transmitter Reflectance				-12	dB	
Transmitter eye mask definition {X1, X2, X3, Y1, Y2, Y3}		Follow CWDM4 MSA				4
Receiver						
Signaling Speed per Lane		25.78125 ± 100 ppm			GBd	5
Lane center wavelengths (range)		1264.5 – 1277.5 1284.5 – 1297.5 1304.5 – 1317.5 1324.5 – 1337.5			nm	
Receive Saturation (OMA) per Lane	R _{max}	2.5			dBm	
Damage threshold per Lane		3.5			dBm	
Unstressed Receiver Sensitivity (OMA) per Lane	R _{xsens}			-11.3	dBm	6
Stressed Receiver Sensitivity (OMA) per Lane	SRS			-8.9	dBm	7
Conditions of stressed receiver sensitivity test:						
Vertical Eye Closure Penalty	VECP	Follow CWDM4 MSA			dB	
Stressed J2 Jitter	J2				UI	
Stressed J4 Jitter	J4				UI	
SRS eye mask definition {X1, X2, X3, Y1, Y2, Y3}		Follow CWDM4 MSA				
LOS De-Assert	LOS _D			-12.8	dBm	
LOS Assert	LOS _A	-24		-14	dBm	
LOS Hysteresis			1.5		dB	

Notes:

1. Transmitter consists of 4 lasers operating at 25.78Gb/s each.
2. At maximum TDP.
3. TDP value does not include MPI penalty.
4. Hit ratio of 5×10^{-5} , per IEEE.
5. Receiver consists of 4 photodetectors operating at 25.78Gb/s each.
6. Sensitivity is specified at 5×10^{-5} BER.
7. Measured with 4WDM MSA³ conformance test signal at TP3 for 5×10^{-5} BER.
8. Power value and power accuracy are with all channels on.

V. General Specifications

Parameter	Symbol	Min	Typ	Max	Units	Ref.
Bit Rate (all wavelengths combined)	BR			103.1	Gb/s	
Bit Error Ratio @25.78Gb/s	BER			5×10^{-5}		1
Maximum Supported Reach						
Fiber Type						
SMF per G.652	LossBdgt			6.5	dB	2

Notes:

1. Tested with a $2^{31} - 1$ PRBS.
2. The maximum informative link length is 10km. The option to bypass RS-FEC is not supported. Loss budget may include up to 1dB MPI loss penalty with worse case Transmitter and worst case connector MPI.

VI. Environmental Specifications

Finisar FTLC1155RGPLD QSFP28 transceivers have an operating case temperature range of -40°C to +85°C.

Parameter	Symbol	Min	Typ	Max	Units	Ref.
Case Operating Temperature	T _{op}	-40		+85	°C	
Storage Temperature	T _{sto}	-40		+85	°C	

VII. Regulatory Compliance

Finisar FTLC1155RGPLD QSFP28 transceivers are Class 1 Laser Products. They are certified per the following standards:

Feature	Agency	Standard
Laser Eye Safety	FDA/CDRH	CDRH 21 CFR 1040 and Laser Notice 50
	CSA	IEC60825-2:2004+A1+A2
	TüV	EN60825-1:2014 & EN60825-2:2006+A1+A2
Electrical Safety	CSA	IEC60950-1:2005+A1+A2
	TüV	EN60950-1:2006+A11+A1+A12+A2
	UL/CSA	CLASS 3862.13 & CLASS 3862.93

Copies of the referenced certificates are available at Finisar Corporation upon request.

VIII. Digital Diagnostics Functions

FTLC1155RGPLD QSFP28 transceivers support the I2C-based diagnostics interface specified by the SFF Committee¹. See also Finisar Application Notes AN-2153⁵ and AN-2154⁶.

IX. Memory Contents

Per SFF-8665 Specification¹. See Finisar Application Note AN-2154⁶.

XI. Mechanical Specifications

Finisar FTLC1155RGPLD transceivers are compatible with the QSFP28 Specification for pluggable form factor modules.

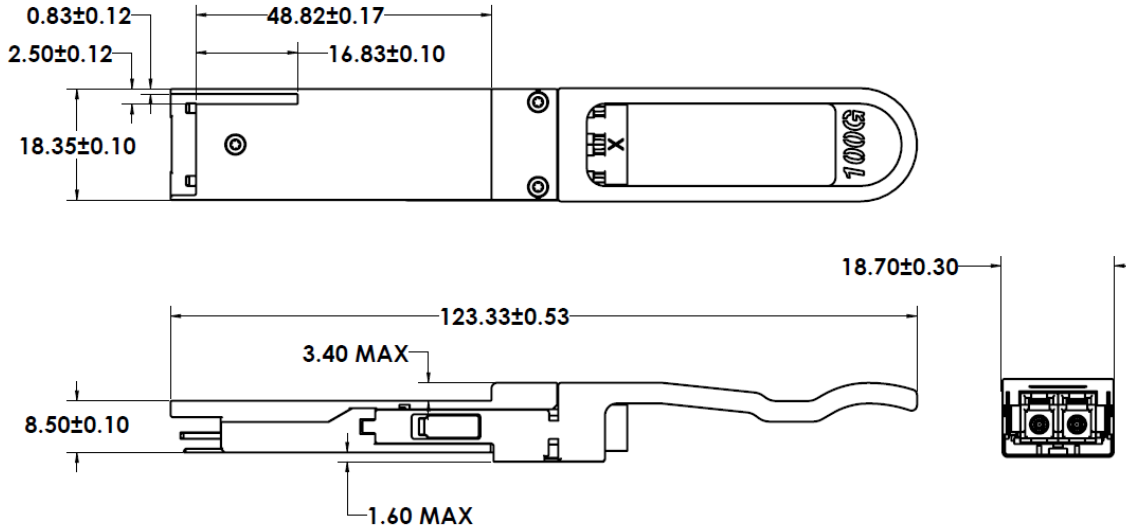

Figure 2. FTLC1155RGPLD Mechanical Dimensions.

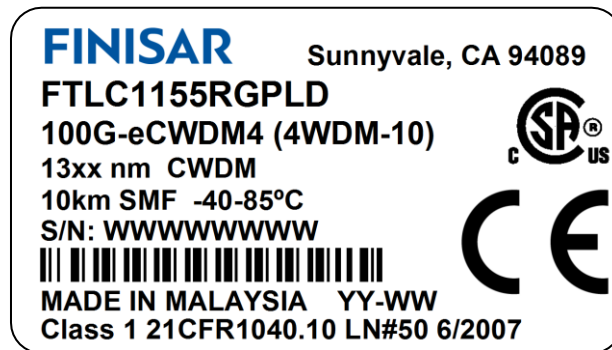

Figure 3. Product Label (Not to Scale)

XII. References

1. SFF-8665: “QSFP+ 28Gb/s 4X Pluggable Transceiver Solution (QSFP28)”, Rev 1.9, June 29, 2015 and associated SFF documents referenced therein:
 - i. SFF-8661
 - ii. SFF-8679
 - iii. SFF-8636
 - iv. SFF-8662
 - v. SFF-8663
 - vi. SFF-8672
 - vii. SFF-8683
2. 100G CWDM4 MSA Technical Specifications: 2km Optical Specifications, Rev. 1.1, November 23, 2015.
3. 100G 4WDM-10 MSA Technical Specifications: 10km Optical Specifications, Rev 1.0, March 10, 2017.
4. IEEE P802.3bm, Annex 83E, CAUI-4 Interface.
5. Application Note AN-2153, Initialization, Finisar Corporation.
6. Application Note AN-2154, EEPROM Map, Finisar Corporation.
7. Directive 2011/65/EU of the European Parliament and of the Council, “on the restriction of the use of certain hazardous substances in electrical and electronic equipment,” July 1, 2011.
8. Application Note AN-2038: Finisar Implementation Of RoHS Compliant Transceivers, Finisar Corporation.

For More Information:

Finisar Corporation
1389 Moffett Park Drive
Sunnyvale, CA 94089-1133
Tel. 1-408-548-1000
Fax 1-408-541-6138
sales@finisar.com
www.finisar.com