

Product Specification

25G Ethernet RoHS Compliant Long Wavelength SFP28 Transceiver

FTLF1436W5BTD

PRODUCT FEATURES

- Up to 25.78 Gb/s bi-directional data links
- Hot-pluggable SFP+ footprint
- Built-in digital diagnostic functions
- 1310nm DFB laser transmitter
- Duplex LC connector
- RoHS compliant
- Up to 300m on 9/125µm SMF
- Metal enclosure, for lower EMI
- 1.5W maximum power consumption with established link
- Single 3.3V power supply
- Operating temperature range:
-40°C to 85°C



APPLICATIONS

- 25GE
- eCPRI & CPRI

Finisar's FTLF1436W5BTD SFP28 transceivers are designed for use in Ethernet links up to 25.78 Gb/s data rate and up to 300m link length. They are compliant SFF-8472 Rev 12.2^b, and compatible with SFF-8432^a and applicable portions of SFF-8431 Rev. 3.0^c. The product is RoHS compliant and lead-free per Directive 2011/96/EU^d. See Finisar Application Note AN-2038 for more details.

PRODUCT SELECTION

FTLF1436W5BTD

I. Pin Descriptions

Pin	Symbol	Name/Description	Ref.
1	V _{EET}	Transmitter Ground (Common with Receiver Ground)	1
2	T _{FAULT}	Transmitter Fault.	2
3	T _{DIS}	Transmitter Disable. Laser output disabled on high or open.	3
4	SDA	2-wire Serial Interface Data Line (MOD-DEF2)	4
5	SCA	2-wire Serial Interface Clock (MOD-DEF1)	4
6	MOD_ABS	Module Absent, connected to V _{EET} or V _{EER}	4
7	RS0	Rx Rate Select: Open or Low = 10.3 Gb/s or 9.8Gb/s (Low Bandwidth) High = 25.78 Gb/s or 24.33Gb/s (High Bandwidth)	5
8	LOS	Loss of Signal indication. Logic 0 indicates normal operation.	6
9	RS1	Tx Rate Select: Open or Low = 10.3 Gb/s or 9.8Gb/s (Low Bandwidth) High = 25.78 Gb/s or 24.33Gb/s (High Bandwidth)	5
10	V _{EER}	Receiver Ground (Common with Transmitter Ground)	1
11	V _{EER}	Receiver Ground (Common with Transmitter Ground)	1
12	RD-	Receiver Inverted DATA out. AC Coupled	
13	RD+	Receiver Non-inverted DATA out. AC Coupled	
14	V _{EER}	Receiver Ground (Common with Transmitter Ground)	1
15	V _{CCR}	Receiver Power Supply	
16	V _{CCT}	Transmitter Power Supply	
17	V _{EET}	Transmitter Ground (Common with Receiver Ground)	1
18	TD+	Transmitter Non-Inverted DATA in. AC Coupled.	
19	TD-	Transmitter Inverted DATA in. AC Coupled.	
20	V _{EET}	Transmitter Ground (Common with Receiver Ground)	1

Notes:

- Circuit ground is internally isolated from chassis ground.
- T_{FAULT} is an open collector/drain output, which should be pulled up with a 4.7k – 10k Ohms resistor on the host board if intended for use. Pull up voltage should be between 2.0V to V_{CC} + 0.3V. A high output indicates a transmitter fault caused by either the TX bias current or the TX output power exceeding the preset alarm thresholds. A low output indicates normal operation. In the low state, the output is pulled to <0.8V.
- Laser output disabled on T_{DIS} >2.0V or open, enabled on T_{DIS} <0.8V.
- Should be pulled up with 4.7k – 10kohms on host board to a voltage between 2.0V and 3.6V. MOD_ABS pulls line low to indicate module is plugged in.
- Rate select can also be set through the 2-wire bus in accordance with SFF-8472 v. 12.1°. Rx Rate Select is set at Bit 3, Byte 110, Address A2h. Tx Rate Select is set at Bit 3, Byte 118, Address A2h. Note: writing a “1” selects maximum bandwidth operation. Rate select is the logic OR of the input state of Rate Select Pin and 2-wire bus.
- LOS is open collector output. Should be pulled up with 4.7k – 10kohms on host board to a voltage between 2.0V and 3.6V. Logic 0 indicates normal operation; logic 1 indicates loss of signal.

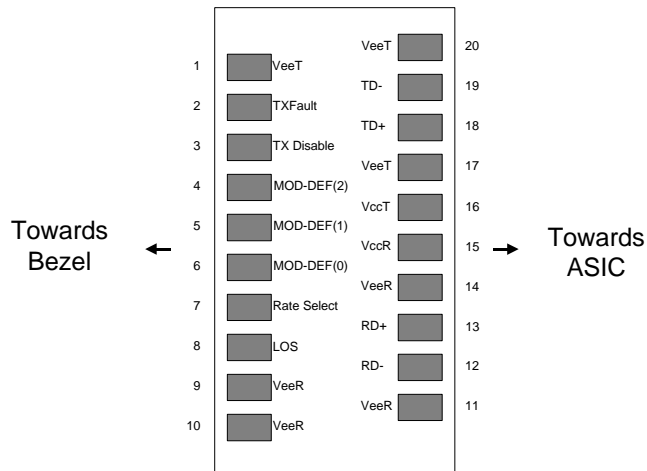

Diagram of Host Board Connector Block Pin Numbers and Names

II. Absolute Maximum Ratings

Parameter	Symbol	Min	Typ	Max	Unit	Ref.
Maximum Supply Voltage	V _{cc}	-0.5		4.0	V	
Storage Temperature	T _S	-40		85	°C	
Case Operating Temperature	T _C	-40		85	°C	
Relative Humidity (Non-condensing)	RH	0		85	%	1

Notes:

1. Non Condensing

III. Electrical Characteristics (T_A, V_{CC} = 3.15 to 3.46 Volts)

Parameter	Symbol	Min	Typ	Max	Unit	Ref.
Supply Voltage	V _{cc}	3.15		3.46	V	
Supply Current	I _{cc}			433	mA	1
Transmitter						
Input differential impedance	R _{in}		100		Ω	2
Single-ended data input swing	V _{in,pp}	125		450	mV	3
Inner Eye Height (@ 25.78Gb/s)	EH6	95			mV	3
Transmit Disable Voltage	V _D	2		V _{cc}	V	4
Transmit Enable Voltage	V _{EN}	V _{ee}		V _{ee} +0.8	V	
Receiver						
Single ended data output swing	V _{out,pp}	185		425	mV	5
LOS Fault	V _{LOS fault}	2		V _{ccHOST}	V	6
LOS Normal	V _{LOS norm}	V _{ee}		V _{ee} +0.8	V	6
Power Supply Rejection	PSR	100			mVpp	7

Notes:

1. With established link, the total power dissipation shall not exceed 1.3W above 0C.
2. Connected directly to TX data input pins. AC coupling from pins into laser driver IC.
3. The minimum value represents the minimum outer eye amplitude. Inner Eye Height represent the high loss case.
4. Or open circuit.
5. Into 100 ohms differential termination.
6. LOS is an open collector output. Should be pulled up with 4.7k – 10kohms on the host board. Normal operation is logic 0; loss of signal is logic 1. Maximum pull-up voltage is 5.5V.
7. Receiver sensitivity is compliant with power supply sinusoidal modulation of 20 Hz to 1.5 MHz up to specified value applied through the recommended power supply filtering network.

IV. Optical Characteristics (T_A, V_{CC} = 3.15 to 3.46 Volts)

Parameter	Symbol	Min	Typ	Max	Unit	Ref.
Transmitter						
Average Output Power, 25.78Gb/s or 24.33Gb/s	P _{OUT}	-6.8		2.0	dBm	1,2,3
Optical Wavelength	λ	1260	1310	1360	nm	
Spectral Width (-20dB)	σ			1	nm	
Sidemode Supression ratio	SSR _{min}	30			dB	
Optical Modulation Amplitude, 25.78Gb/s or 24.33Gb/s	OMA	-6		2.2	dBm	
Launch Power in OMA-TDP (min)		-7			dB	
Transmitter Dispersion Penalty, 25.78Gb/s or 24.33Gb/s	TDP			3.5	dB	
Extinction Ratio	ER	2.5			dB	
Transmitter eye mask definition {X1, X2, X3, Y1, Y2, Y3}		0.35, 0.44, 0.47, 0.35, 0.35, 0.56				4
Relative Intensity Noise	RIN ₂₀ OMA			-130	dB/Hz	
Transmitter Return Loss				26	dB	
Average Launch Power of OFF Transmitter				-30	dBm	
Optical Return Loss tolerance				20	dB	
Receiver						
Unstressed Receiver OMA Sensitivity , 25.78Gb/s or 24.33Gb/s	R _x SENS			-10.5	dBm	5
Maximum Receiver Power OMA				2.2	dBm	
Average Receiver Power 25.78Gb/s or 24.33Gb/s	R _x MAX	-10.3		2.0	dBm	3,5
Damage threshold		3			dBm	
Optical Center Wavelength	λ _c	1260		1360	nm	
LOS De-Assert	LOS _D			-14	dBm	
LOS Assert	LOS _A	-27			dBm	
LOS Hysteresis		0.5			dB	
Receiver Reflectance				-26	dB	

Notes:

- Class 1 Laser Safety per FDA/CDRH and EN (IEC) 60825 regulations.
- High Bandwidth Mode. Class 1 Laser Safety per FDA/CDRH and EN (IEC) 60825 regulations.
- For information only
- Hit ratio 5E⁻⁵ hits per sample
- Test at 25.78Gb/s 5E⁻⁵ BER, per IEEE802.3cc

V. General Specifications

Parameter	Symbol	Min	Typ	Max	Units	Ref.
Data Rate	BR		25.78		Gb/sec	
Bit Error Rate 25.78Gb/s or 24.33Gb/s	BER			5E(-5)		1,2

Fiber Length	L			300	m	3
--------------	---	--	--	-----	---	---

Notes:

1. Tested with a PRBS $2^{31}-1$ test pattern @ 25.78Gb/s.
2. 9.8304G, 10.1376G and 10.3125G with CDR bypass.
3. Distances are based on G.652 fiber.

VI. Environmental Specifications

Parameter	Symbol	Min	Typ	Max	Units	Ref.
Case Operating Temperature	T _{op}	-40		85	°C	
Storage Temperature	T _{sto}	-40		85	°C	

VII. Regulatory Compliance

Finisar transceivers are Class 1 Laser Products and comply with US FDA regulations. These products are certified by TÜV and CSA to meet the Class 1 eye safety requirements of EN (IEC) 60825 and the electrical safety requirements of EN (IEC) 60950. Copies of certificates are available at Finisar Corporation upon request.

VIII. Digital Diagnostic Functions

Finisar FTLF1436W5BTD SFP28 transceivers support the 2-wire serial communication protocol as defined in the SFP MSA^e. It is very closely related to the E²PROM defined in the GBIC standard, with the same electrical specifications.

The standard SFP serial ID provides access to identification information that describes the transceiver's capabilities, standard interfaces, manufacturer, and other information.

Additionally, Finisar SFP transceivers provide an enhanced digital diagnostic monitoring interface, which allows real-time access to device operating parameters such as transceiver temperature, laser bias current, transmitted optical power, received optical power and transceiver supply voltage. It also defines a sophisticated system of alarm and warning flags, which alerts end-users when particular operating parameters are outside of a factory set normal range.

The SFP MSA defines a 256-byte memory map in E²PROM that is accessible over a 2-wire serial interface at the 8 bit address 1010000X (A0h). The digital diagnostic monitoring interface makes use of the 8 bit address 1010001X (A2h), so the originally defined serial ID memory map remains unchanged. The interface is identical to, and is thus fully backward compatible with both the GBIC Specification and the SFP Multi Source Agreement. The complete interface is described in Finisar Application Note AN-2030: "Digital Diagnostics Monitoring Interface for SFP Optical Transceivers".

The operating and diagnostics information is monitored and reported by a Digital Diagnostics Transceiver Controller (DDTC) inside the transceiver, which is accessed through a 2-wire serial interface. When the serial protocol is activated, the serial clock signal (SCL, Mod Def 1) is generated by the host. The positive edge clocks data into the SFP transceiver into those segments of the E²PROM that are not write-protected. The negative edge clocks data from the SFP transceiver. The serial data signal (SDA, Mod Def 2) is bi-directional for serial data transfer. The host uses SDA in conjunction with SCL to mark the start and end of serial protocol activation. The memories are organized as a series of 8-bit data words that can be addressed individually or sequentially.

For more information, please see the SFP MSA documentation^e and Finisar Application Note AN-2030.

TX Equalization Control

Tx input equalization control can be accessed through 2-wire serial interface at byte address 114 (A2h). Tx input equalization control for 25GE is located at the upper 4 bits of byte 114 (A2h) while the lower 4 bits are reserved for rate low in the case of dual rate application.

RX Emphasis Control

Rx output emphasis control can be accessed through 2-wire serial interface at byte address 115 (A2h). Rx output emphasis control for 25GE is located at the upper 4 bits of byte 115 (A2h) while the lower 4 bits are reserved for rate low in the case of dual rate application.

IX. Digital Diagnostic Specifications

FTLF1436W5BTD transceivers can be used in host systems that require either internally or externally calibrated digital diagnostics.

Parameter	Symbol	Units	Min	Max	Accuracy	Ref.
Transceiver Temperature	DDDTemp	°C	-40	+85	±5°C	
Transceiver Supply Voltage	DDDVoltage	V	3.15	3.45	±3%	
Transmitter Bias Current	DDDBias	mA	0	80	±10%	1
Transmitter Output Power	DDDTx-Power	dBm	-7	+3	±3dB	
Receiver Average Optical Input Power	DDDRx-Power	dBm	-11	+3	±3dB	

Notes:

1. Accuracy of Measured Tx Bias Current is 10% of the actual Bias Current from the laser driver to the laser.

X. Mechanical Specifications

Finisar’s FTLF1436W5BTD SFP28 transceivers are compatible with the SFF-8432^b specification for improved pluggable form factor.

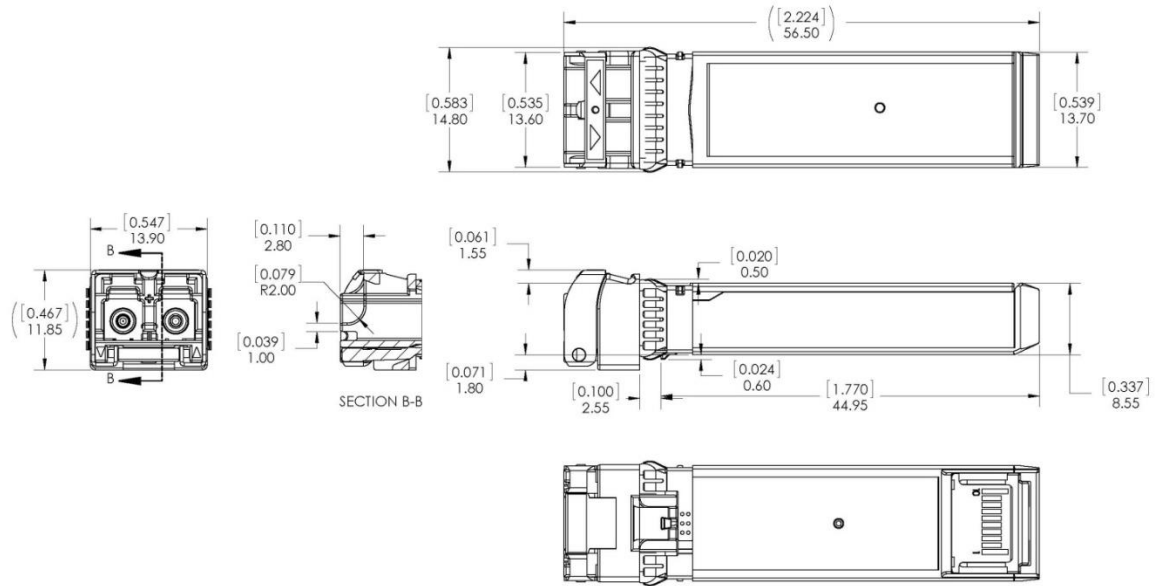

FTLF1436W5BTD

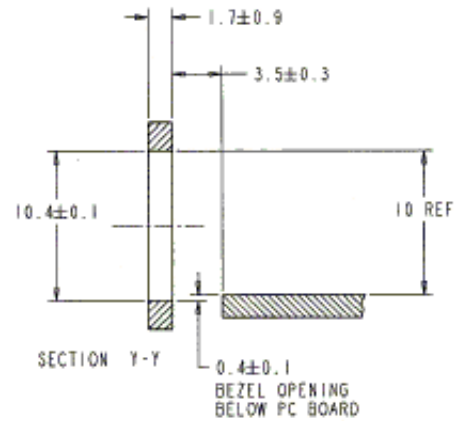
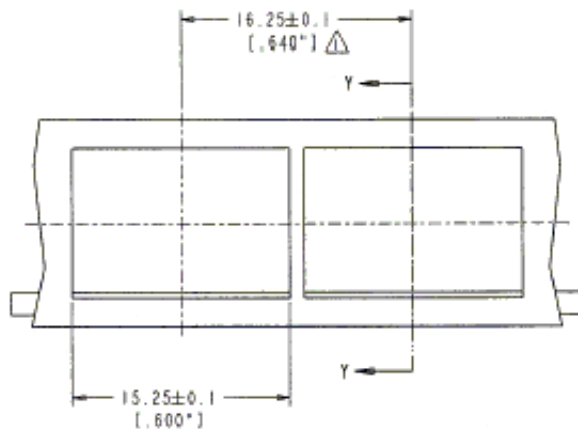
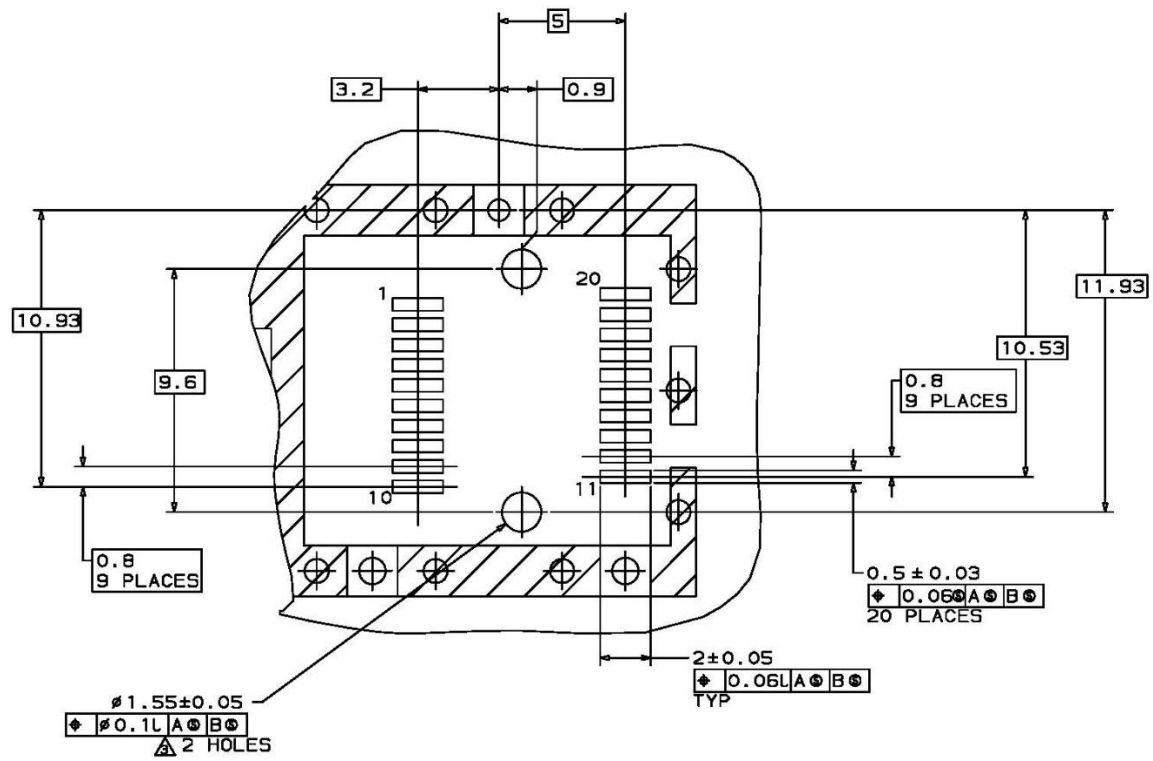

NOTES:

△ MINIMUM PITCH ILLUSTRATED, ENGLISH DIMENSIONS ARE FOR REFERENCE ONLY

2. NOT RECOMMENDED FOR PCI EXPANSION CARD APPLICATIONS

XII. References

- a. “Improved Pluggable Form Factor”, SFF Document Number SFF-8432, Revision 5.0, July 16, 2007.
- b. “Digital Monitoring Interface for Optical Transceivers”, SFF Document Number SFF-8472, Revision 12.2, 2014.
- c. “Enhanced Small Form Factor Pluggable Module ‘SFP+ ‘”, SFF Document Number SFF-8431, Revision 4.1, July 6, 2009; Addendum Jun 21, 2013.
- d. Directive 2011/65/EU of the European Council Parliament and of the Council, “on the restriction of the use of certain hazardous substances in electrical and electronic equipment”. 08-June 2011, which supercedes the previous ROHS Directive 2002/95/EC.
- e. Small Form Factor Pluggable (SFP) Transceiver Multi-source Agreement (MSA), September 14, 2000 which is available as SFF Document Number INF-8074, Revision 1.0 May 12, 2001
- f. “0.8mm Card Edge Connector for 16Gb/s Applications”, SFF Document Number SFF-8081, Revision 0.2, December 21, 2009.
- g. SFF-8402, Revision 0.2

XIII. For More Information

Finisar Corporation
1308 Moffett Park Drive
Sunnyvale, CA 94089-1133
Tel. 1-408-548-1000
Fax 1-408-541-6138
sales@finisar.com
www.finisar.com