ADNS-3000

Low Power Optical Mouse Sensor

Data Sheet



Description

The PixArt Imaging ADNS-3000 is a low power, small form factor optical mouse sensor. It has a new low-power architecture and automatic power management modes, making it ideal for battery, power-sensitive applications – such as cordless input devices.

The ADNS-3000 is capable of high-speed motion detection – up to 30 ips and 20 g. In addition, it has an on-chip oscillator and requires an external resistor to set the LED current.

The ADNS-3000 along with the ADNS-5110-001 lens, or ADNS-5120-002 trim lens and HSDL-4261 IR LED or HLMP-EG3E-xxxxx Red LED form a complete and compact mouse tracking system. There are no moving parts and this translates to high reliability and less maintenance for the end user. In addition, precision optical alignment is not required, facilitating high volume assembly.

The sensor is programmed via registers through a four-wire serial port. It is housed in an 8-pin staggered dual in-line package (DIP).

Features

- Low Power Architecture
- Small Form Factor
- Programmable Periods / Response Times and Downshift Times from one mode to another for the Power-saving Modes
- High Speed Motion Detection up to 30 ips and 20 g
- External Interrupt Output for Motion Detection
- Internal Oscillator – no clock input needed
- Selectable Resolution of up to 2000 cpi
- Operating Voltage: as low as 1.7 V
- Four-wire Serial Port Interface

Applications

- Optical mice and optical trackballs
- Integrated input devices
- Battery-powered input devices

ADNS-3000 Low Power Optical Mouse Sensor

Theory of Operation

The ADNS-3000 is based on Optical Navigation Technology, which measures changes in position by optically acquiring sequential surface images (frames) and mathematically determining the direction and magnitude of movement.

The ADNS-3000 contains an Image Acquisition System (IAS), a Digital Signal Processor (DSP), and a four wire serial port.

The IAS acquires microscopic surface images via the lens and illumination system. These images are processed by the DSP to determine the direction and distance of motion. The DSP calculates the Dx and Dy relative displacement values

An external microcontroller reads and translates the Dx and Dy information from the sensor serial port into PS2, USB, or RF signals before sending them to the host PC.

Pinout of ADNS-3000 Optical Mouse Sensor

Pin	Name	Input/Output	Description
1	MISO	O	Serial Data Output (Master In/Slave Out)
2	LED	I	LED Illumination
3	MOTION	O	Motion Interrupt Output (Default active low, edge triggered)
4	NCS	I	Chip Select (Active low input)
5	SCLK	I	Serial Clock
6	GND	I	Ground
7	VDD	I	Supply Voltage
8	MOSI	I	Serial Data Input (Master Out/Slave In)

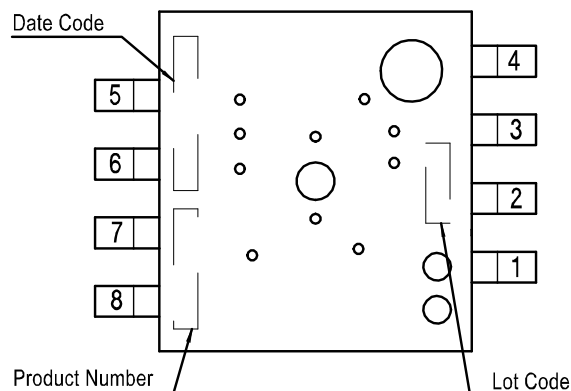

Item	Marking	Remarks
Product Number	A3000	
Date Code	XYWWZ	X = Subcon Code YYWW = Date Code Z = Sensor Die Source
Lot Code	VVV	Numeric

Figure 1. Package Outline Drawing (Top View)

ADNS-3000 Low Power Optical Mouse Sensor

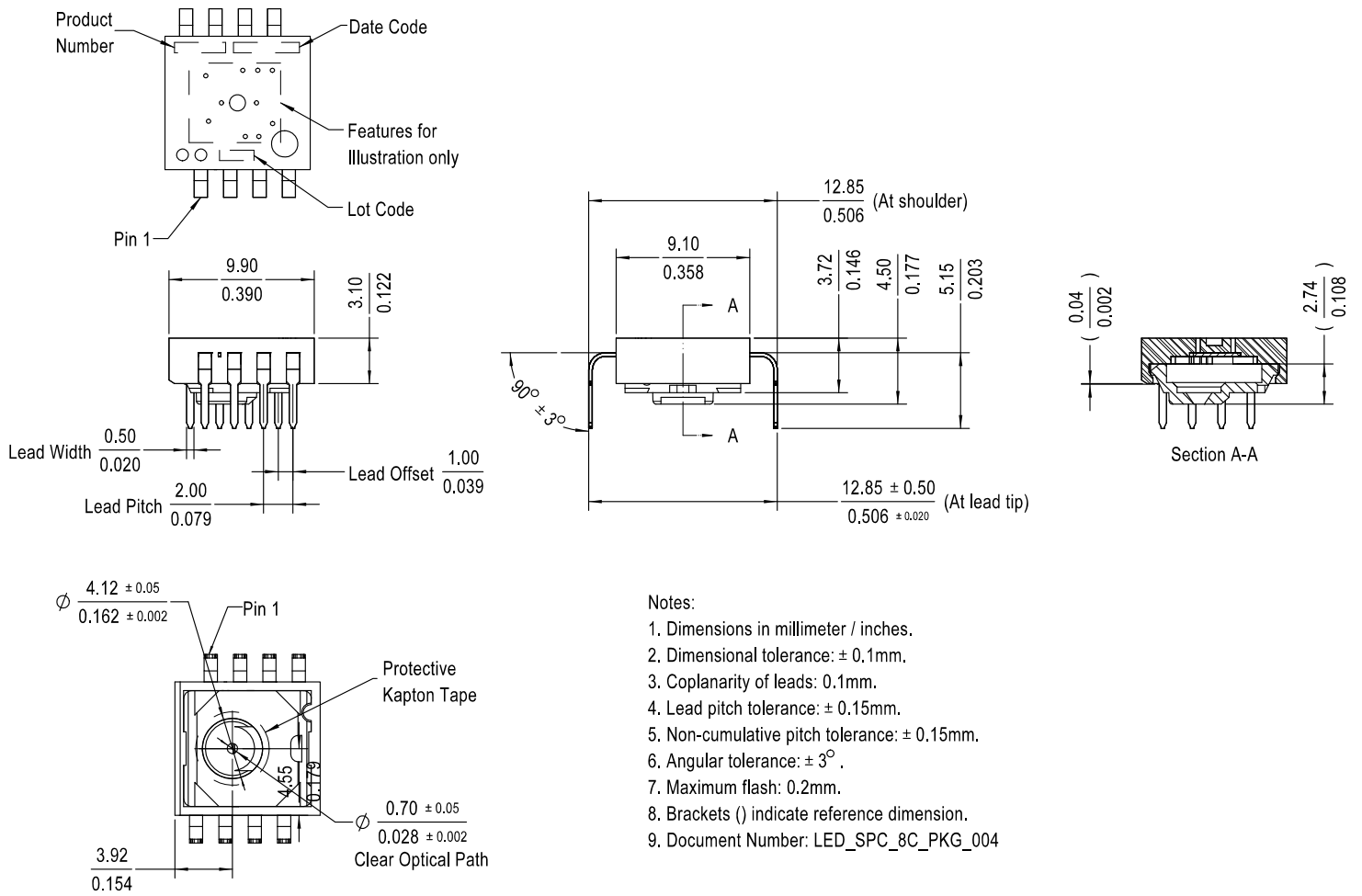

Figure 2. Package Outline Drawing

CAUTION: It is advised that normal static precautions be taken in handling and assembling of this component to prevent damage and/or degradation which may be induced by ESD.

ADNS-3000 Low Power Optical Mouse Sensor

Overview of Optical Mouse Sensor Assembly

PixArt Imaging provides an IGES file drawing describing the base plate molding features for lens and PCB alignment. The ADNS-3000 sensor is designed for mounting on a through-hole PCB, looking down. There is an aperture stop and features on the package that align to the lens. The ADNS-5110-001 and ADNS-5120-002 lens provides optics for the imaging of the surface as well as the illumination of the surface at the optimum angle. Features on the lens align, base it to the sensor plate, and clip with the LED. The LED clip holds the LED in relation to the lens. The LED must be inserted into the clip and the LED's leads formed prior to loading on the PCB. The LEDs recommended for illumination include, HSDL-4261 IR LED HLMP-EG3E-xxxxx Red LED.

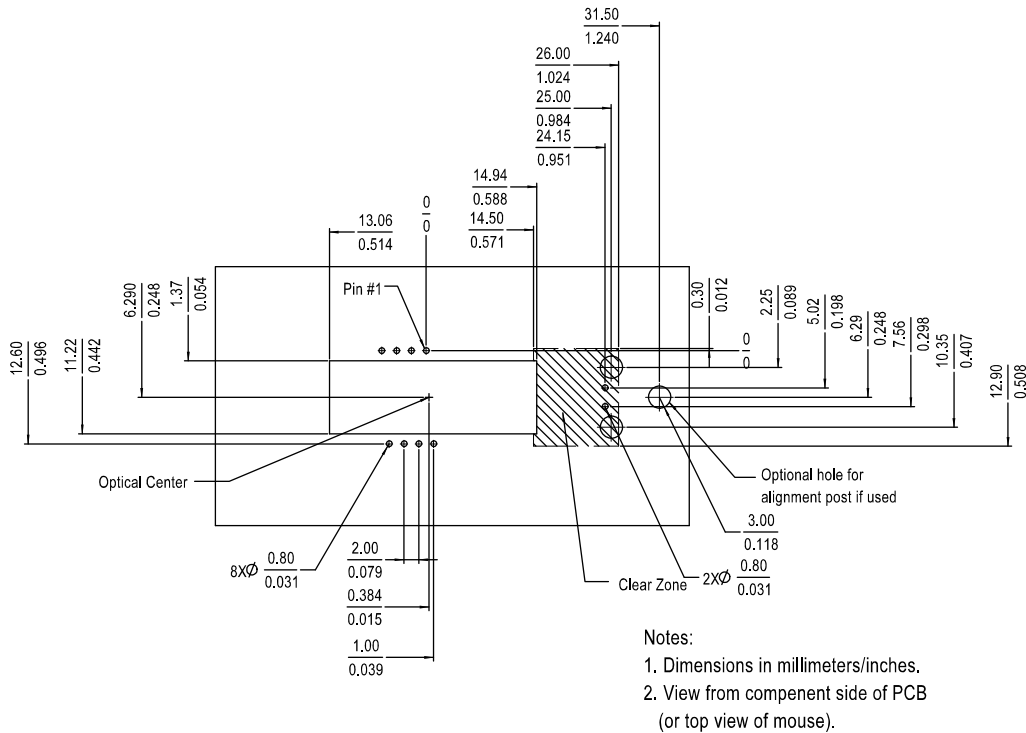

Figure 3. Recommended PCB Mechanical Cutouts and Spacing

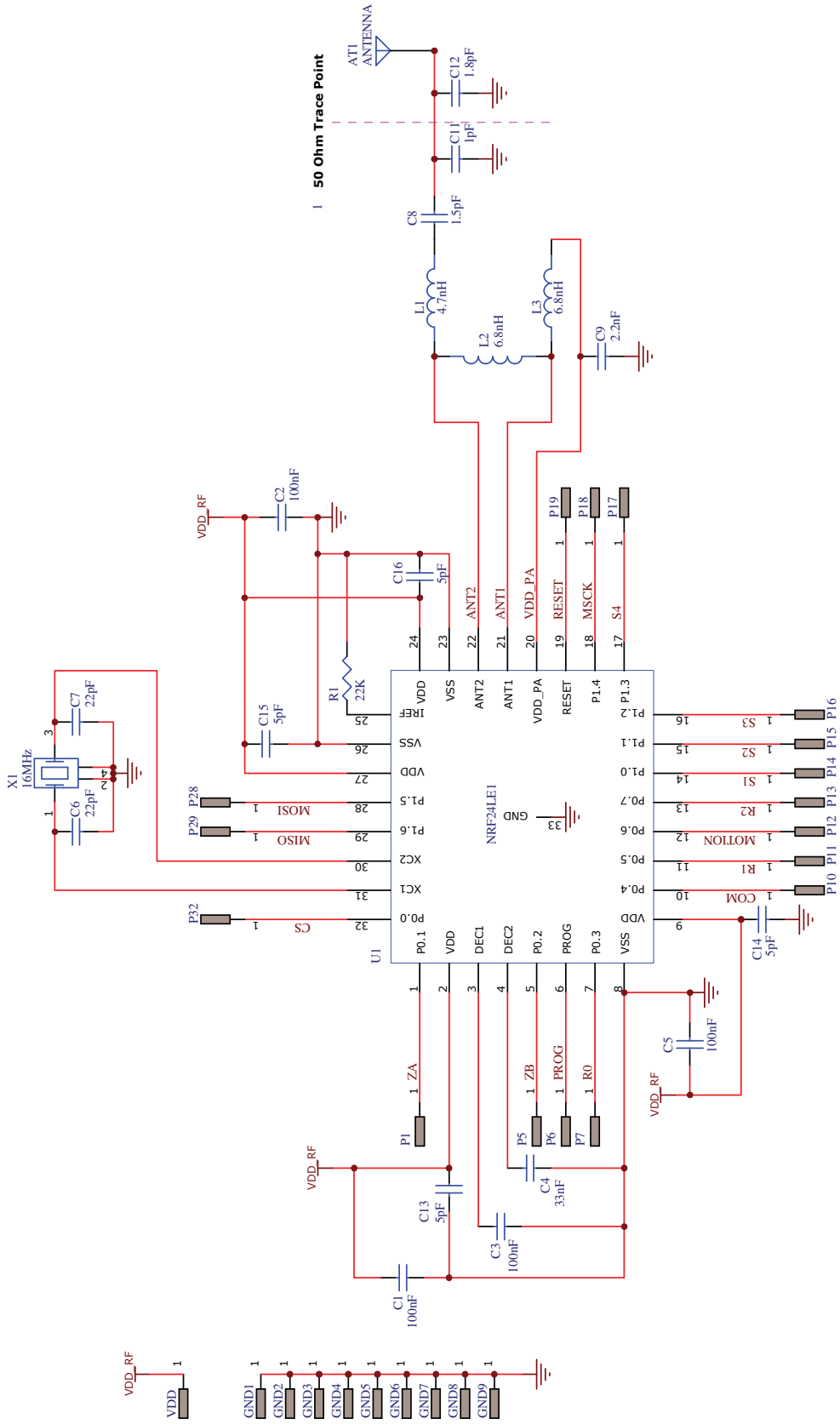

Figure 8b. Schematic diagram of the RF module on the mainboard

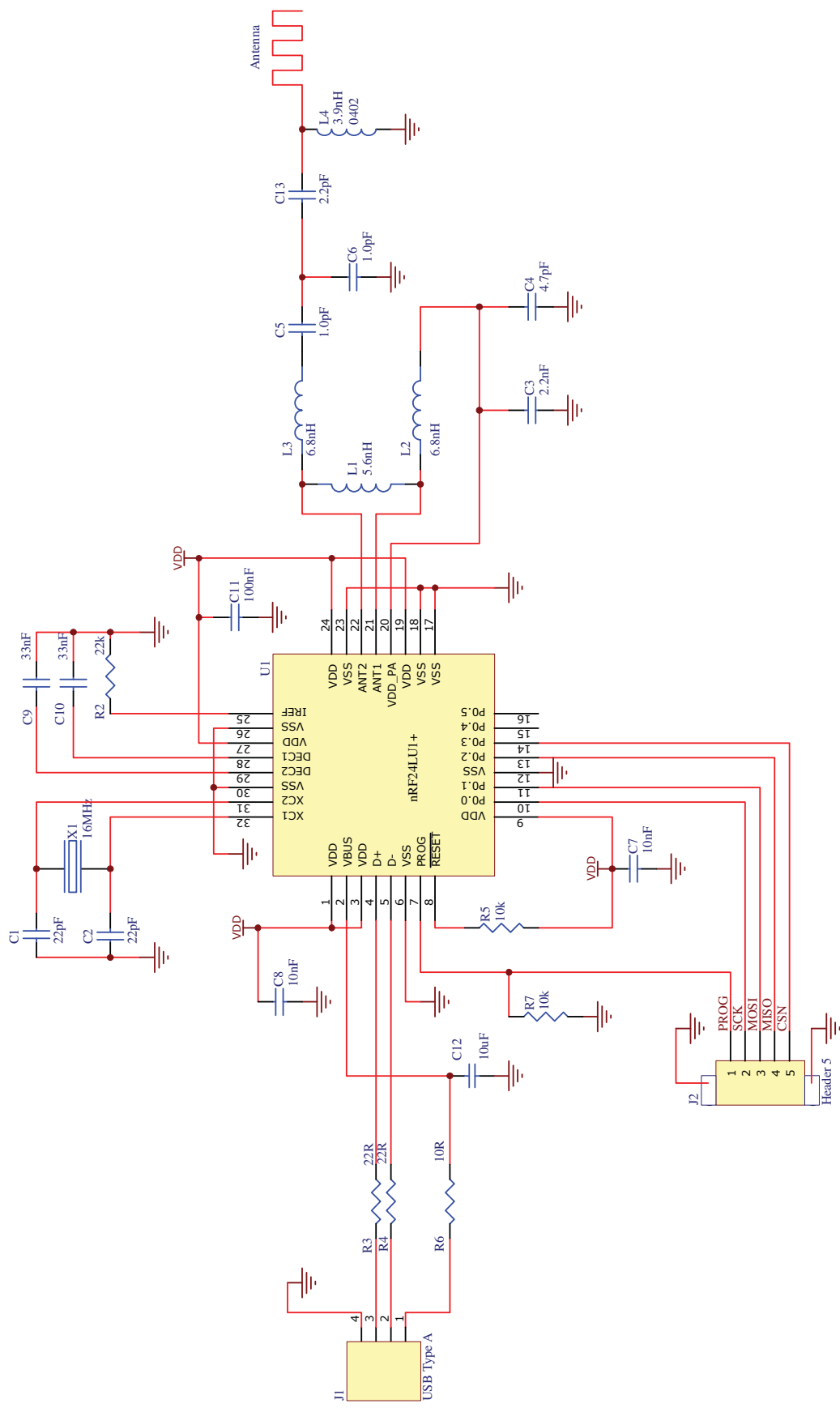

Figure 8C. Schematic diagram of the dongle

Design Considerations for Improved ESD Performance

For improved electrostatic discharge performance, typical creepage and clearance distance are shown in the table below. Assumption: base plate construction is as per the PixArt Imaging supplied IGES file and ADNS-5110-001 or ADNS-5120-002 lens. Note that the lens material is polycarbonate or polystyrene HH30. Therefore, cyanoacrylate based adhesives or other adhesives that may damage the lens should **NOT** be used.

Typical	Distance (mm)
Creepage	16.0
Clearance	2.0

Regulatory Requirements

- Passes FCC B and worldwide analogous emission limits when assembled into a mouse with shielded cable and following PixArt Imaging recommendations.
- UL flammability level UL94 V-0.

Table 1. Absolute Maximum Ratings

Parameter	Symbol	Minimum	Maximum	Units	Notes
Storage Temperature	T _S	-40	85	°C	
Operating Temperature	T _A	-15	55	°C	
Lead Solder Temperature	V _O		260	°C	For 10 seconds, 1.6 mm below seating plane.
Supply Voltage	V _{DD}	-0.5	2.2	V	
ESD			2	kV	All pins, human body model JESD22-A114
Input Voltage	V _{IN}	-0.5	2.1	V	All I/O pins

Table 2. Recommended Operating Condition

Parameter	Symbol	Min	Typ.	Max	Units	Notes
Operating Temperature	T _A	0		40	°C	
Power Supply Voltage	V _{DD}	1.7	1.8	2.1	V	
Power Supply Rise Time	T _{RT}	0.15		20	ms	0 to V _{DD} min
Supply Noise (Sinusoidal)	V _{NA}			100	mVp-p	10 kHz –50 MHz
Serial Port Clock Frequency	f _{SCLK}			1	MHz	50% duty cycle
Distance from Lens Reference Plane to Tracking Surface (Z)	Z	2.3	2.4	2.5	mm	
Speed ¹	S	0		30	ips	At default frame rate
Acceleration	a			20	g	At run mode
Load Capacitance	C _{out}			100	pF	MISO and MOTION

Note:

1. For higher than 500 dpi setting, use 12-bit motion reporting to achieve the maximum speed

ADNS-3000 Low Power Optical Mouse Sensor

Table 4. DC Electrical Specifications

Electrical characteristics over recommended operating conditions. Typical values at 25° C, VDD = 1.9 V, VDD_{LED} = 1.9 V, IRLLED HSDL-4261, I_{LED DC} = 5mA

Parameter	Symbol	Min	Typ.	Max	Units	Notes
DC Supply Current in Various Mode	I _{DD_AVG}		1.44		mA	Average sensor current at max frame rate. No load on MISO
	I _{DD_REST1}		108		μA	
	I _{DD_REST2}		28		μA	
	I _{DD_REST3}		12		μA	
	I _{DDLED_AVG}		0.3		mA	Average LED current at max frame rate. No load on MISO
	I _{DDLED_REST1}		62		μA	
	I _{DDLED_REST2}		15		μA	
	I _{DDLED_REST3}		4		μA	
Power Down Current			10		μA	
Input Low Voltage	V _{IL}			0.3* V _{DD}	V	SCLK, MOSI, NCS
Input High Voltage	V _{IH}	0.7* V _{DD}			V	SCLK, MOSI, NCS
Input Hysteresis	V _{I_HYS}		200		mV	SCLK, MOSI, NCS
Input Leakage Current	I _{leak}		+/-1	+/-10	μA	V _{in} = VDD or 0V
Output Low Voltage	V _{OL}			0.45	V	I _{out} = 1 mA, MISO, MOTION
Output High Voltage	V _{OH}	V _{DD} -0.45			V	I _{out} = -1 mA, MISO, MOTION
Input Capacitance	C _{in}		50		pF	MOSI, NCS, SCLK

All rights strictly reserved any portion in this paper shall not be reproduced, copied or transformed to any other forms without permission.

PixArt Imaging Inc.

E-mail: fae_service@pixart.com.tw

ADNS-3000 Low Power Optical Mouse Sensor

Registers

The ADNS-3000 registers are accessible via the serial port. The registers are used to read motion data and status as well as to set the device configuration.

Address	Register Name	Register Description	Read/Write	Default Value
0x00	PROD_ID	Product ID	R	0x2A
0x01	REV_ID	Revision ID	R	0x00
0x02	MOTION_ST	Motion Status	R	0x00
0x03	DELTA_X	Lower byte of Delta_X	R	0x00
0x04	DELTA_Y	Lower byte of Delta_Y	R	0x00
0x05	SQUAL	Squal Quality	R	0x00
0x06	SHUT_HI	Shutter Open Time (Upper 8-bit)	R	0x00
0x07	SHUT_LO	Shutter Open Time (Lower 8-bit)	R	0x64
0x08	PIX_MAX	Maximum Pixel Value	R	0xD0
0x09	PIX_ACCUM	Average Pixel Value	R	0x80
0x0a	PIX_MIN	Minimum Pixel Value	R	0x00
0x0b	PIX_GRAB	Pixel Grabber	R/W	0x00
0x0c	DELTA_XY_HIGH	Upper 4 bits of Delta X and Y displacement	R	0x00
0x0d	MOUSE_CTRL	Mouse Control	R/W	0x01
0x0e	RUN_DOWNSHIFT	Run to Rest1 Time	R/W	0x08
0x0f	REST1_PERIOD	Rest1 Period	R/W	0x01
0x10	REST1_DOWNSHIFT	Rest1 to Rest2 Time	R/W	0x1f
0x11	REST2_PERIOD	Rest2 Period	R/W	0x09
0x12	REST2_DOWNSHIFT	Rest2 to Rest3 Time	R/W	0x2f
0x13	REST3_PERIOD	Rest3 Period	R/W	0x31
0x22	PERFORMANCE	Performance	R/W	0x00
0x3a	RESET	Reset	W	0x00
0x3f	NOT_REV_ID	Inverted Revision ID	R	0xff
0x40	LED_CTRL	LED Control	R/W	0x00
0x41	MOTION_CTRL	Motion Control	R/W	0x40
0x42	BURST_READ_FIRST	Burst Read Starting Register	R/W	0x03
0x45	REST_MODE_CONFIG	Rest Mode Configuration	R/W	0x00
0x63	MOTION_BURST	Burst Read	R	0x00

All rights strictly reserved any portion in this paper shall not be reproduced, copied or transformed to any other forms without permission.

PixArt Imaging Inc.

E-mail: fae_service@pixart.com.tw