

PMW3320DB-TYDU

Entry-Gaming Optical Navigation Sensor



General Description

The PixArt Imaging PMW3320DB-TYDU is a small form factor entry-gaming optical navigation sensor. It is housed in an 8-pin staggered dual in-line package (DIP). It is capable of high-speed motion detection up to 80ips and 20g; suitable for both wired and wireless gaming navigation system. The low power management in wireless mode can be customized to suit user preferences. In addition, it has an on-chip oscillator and LED driver to minimize external components.

PMW3320DB-TYDU sensor along with LM31-LNG lens, LED clip, and HSDL-4261 IR LED forms a complete and compact mouse tracking system. There are no moving parts, which translates to high reliability and less maintenance for the end user. Precision optical alignment is not required, thus facilitating high volume assembly.

General Description

- Small Form Factor or Package - 8-pin DIP
- Operating Voltage: 2.1V – 3.4V
- High Speed Motion Detection up to 80ips and 20g.
- Selectable Resolutions up to 3500cpi
- Three wire Serial Port Interface
- External Interrupt Output for Motion Detection
- Internal Oscillator — no clock input needed
- Minimal number of passive components
- Programmable power modes:
 - Corded Gaming Mode
 - Cordless Gaming Mode
 - Office Mode
- Customizable response time and downshift time for rest modes
- Configurable LED operating mode

Applications

- Wired and Wireless Optical gaming mice and trackballs
- Integrated input devices
- Battery-powered input devices

Key Specification

Supply Voltage	2.1-3.4V
Interface	3-wired SPI Max clock speed : 1 MHz
Tracking Speed	Up to 80ips
Acceleration	Up to 20g
CPI Resolution	Up to 3500cpi with 250 cpi/step
Frame Rate	Max : 5300 fps (frames per sec)
Operating Current	VDD=2.2V Run Avg : 7.9mA REST1 : 1.4mA REST2 : 0.090mA Power down : 15uA *Including 16mA LED current
Package	8-pin DIP

Pin Descriptions

Table 1. Sensor Pinout

Pin No	Pin Name	Input / Output	Description
1	SDIO	I/O	Serial Data Input Output
2	LED	I	LED Illumination Control Input
3	MOTION	O	Motion Interrupt Output (Active Low)
4	NCS	I	Chip Select Input(Active Low)
5	SCLK	I	Serial Clock Input
6	GND	I	Ground
7	VDD	I	Power Supply Voltage
8	REG	O	Regulator Output

Power Supply Range

VDD = 2.05 – 3.45V (including 100mV pk-pk ripple)
 = 2.10 – 3.40V (excluding 100mV noise ripple)

Sensor Orientation

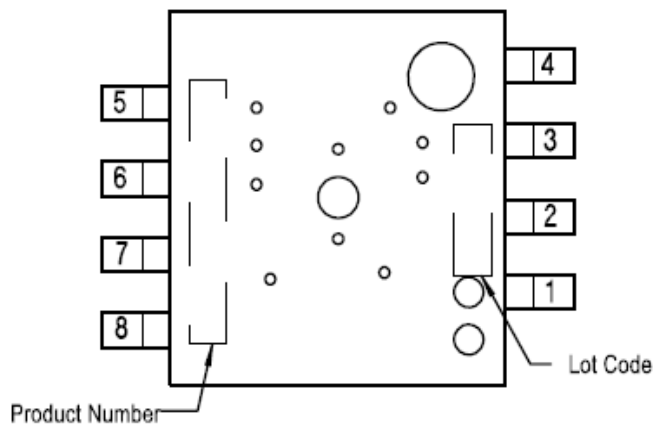

Product Number: PMW3320DB-TYDU
 Lot Code: AYWWXXXXX (A = Assembly house, Y = Year,
 WW = Week, XXXXX = PixArt reference)

Top X-ray view of PMW3320

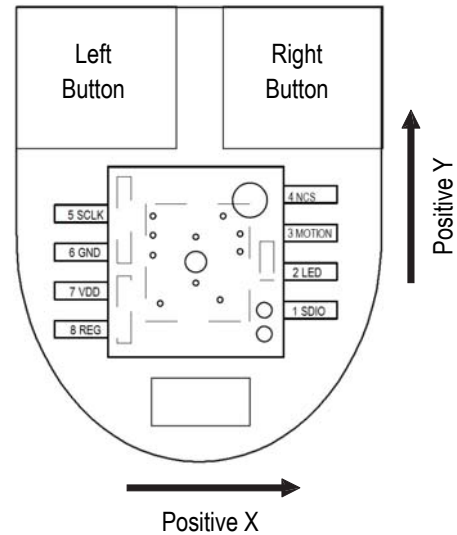

Figure 2. Recommended Sensor Orientation

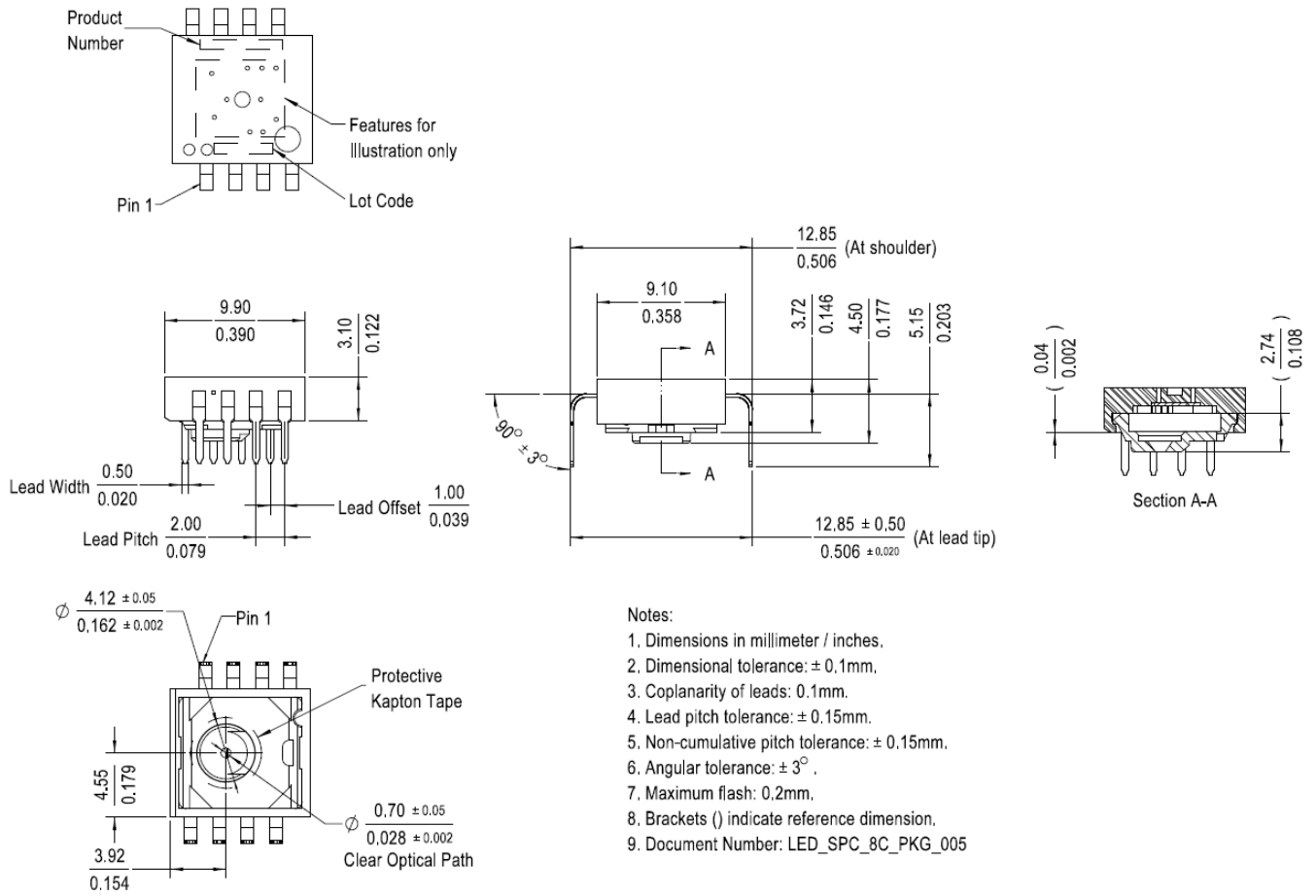

Figure 3. Package Outline Drawing

CAUTION: It is advised that normal static precautions be taken in handling and assembling of this component to prevent damage and/or degradation which may be induced by ESD.

Overview of Optical Mouse Sensor Assembly

PixArt Imaging provides an IGES file drawing describing the base plate molding features for lens and PCB alignment. PMW3320DB-TYDU sensor is designed for mounting on a through-hole PCB. There is an aperture stop and features on the package that align to the lens. The LM31-LNG lens provides optics for the imaging of the surface as well as illumination of the surface at the optimum angle. Features on the lens align it to the sensor, base plate, and clip with the LED. The LED clip holds the LED in relation to the lens. The LED must be inserted into the clip and the LED's leads formed prior to loading on the PCB.

The HSDL-4261 IR LED is recommended for illumination.

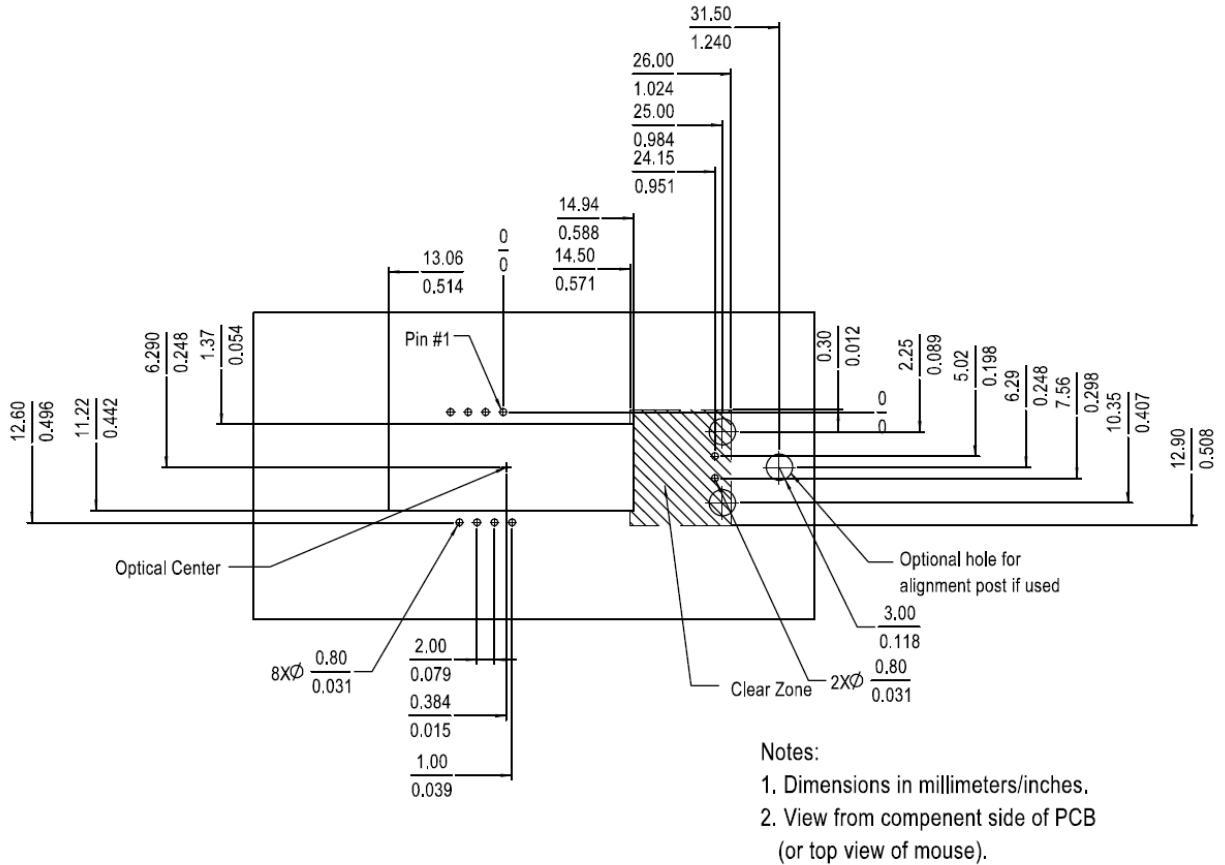

Figure 4. Recommended PCB Mechanical Cutouts and Spacing (Top View)

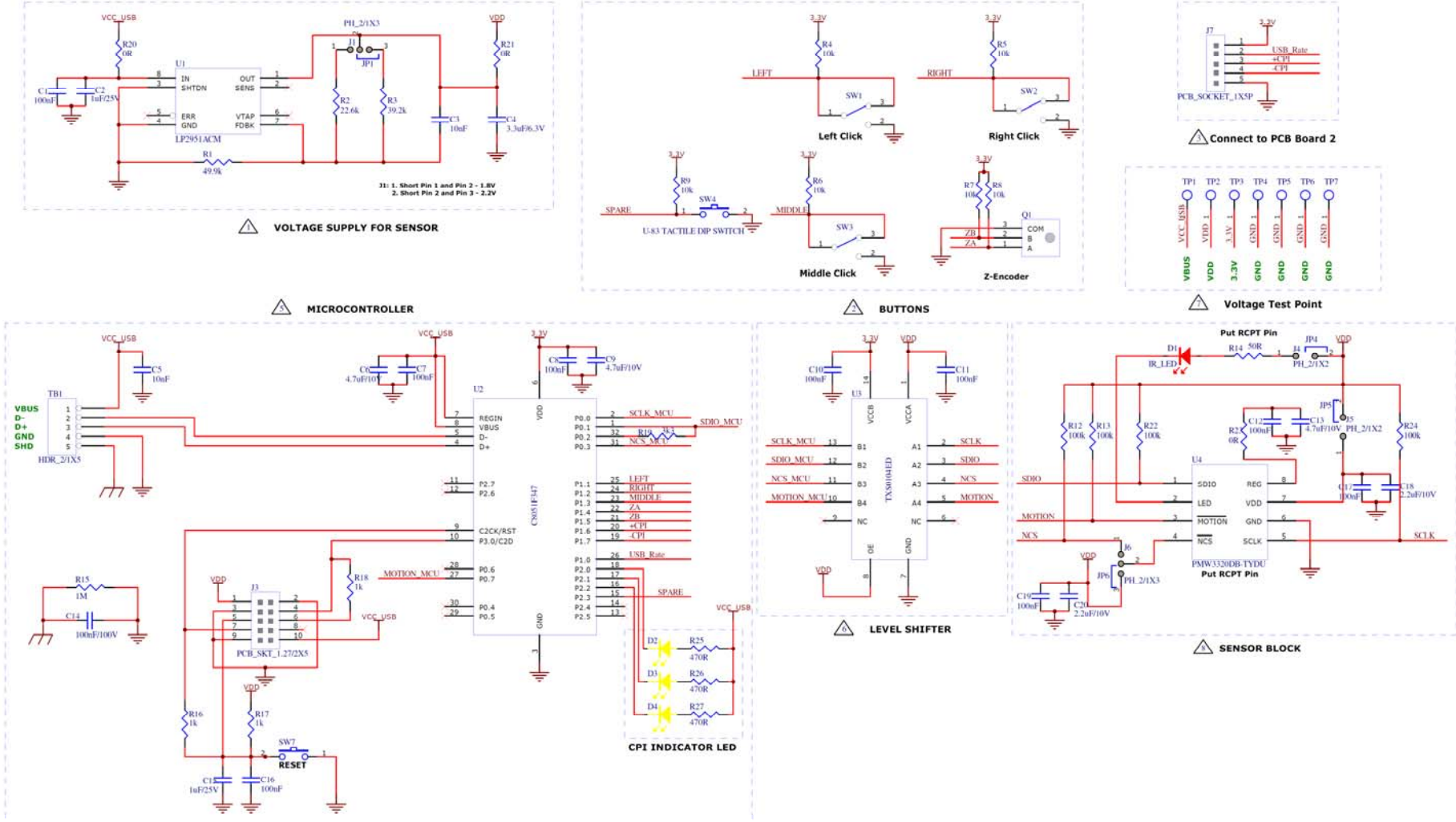

Figure 8. Schematic diagram for interface between PMW3320DB-TYDU and microcontroller with HSDL-4261 IR LED on a corded solution

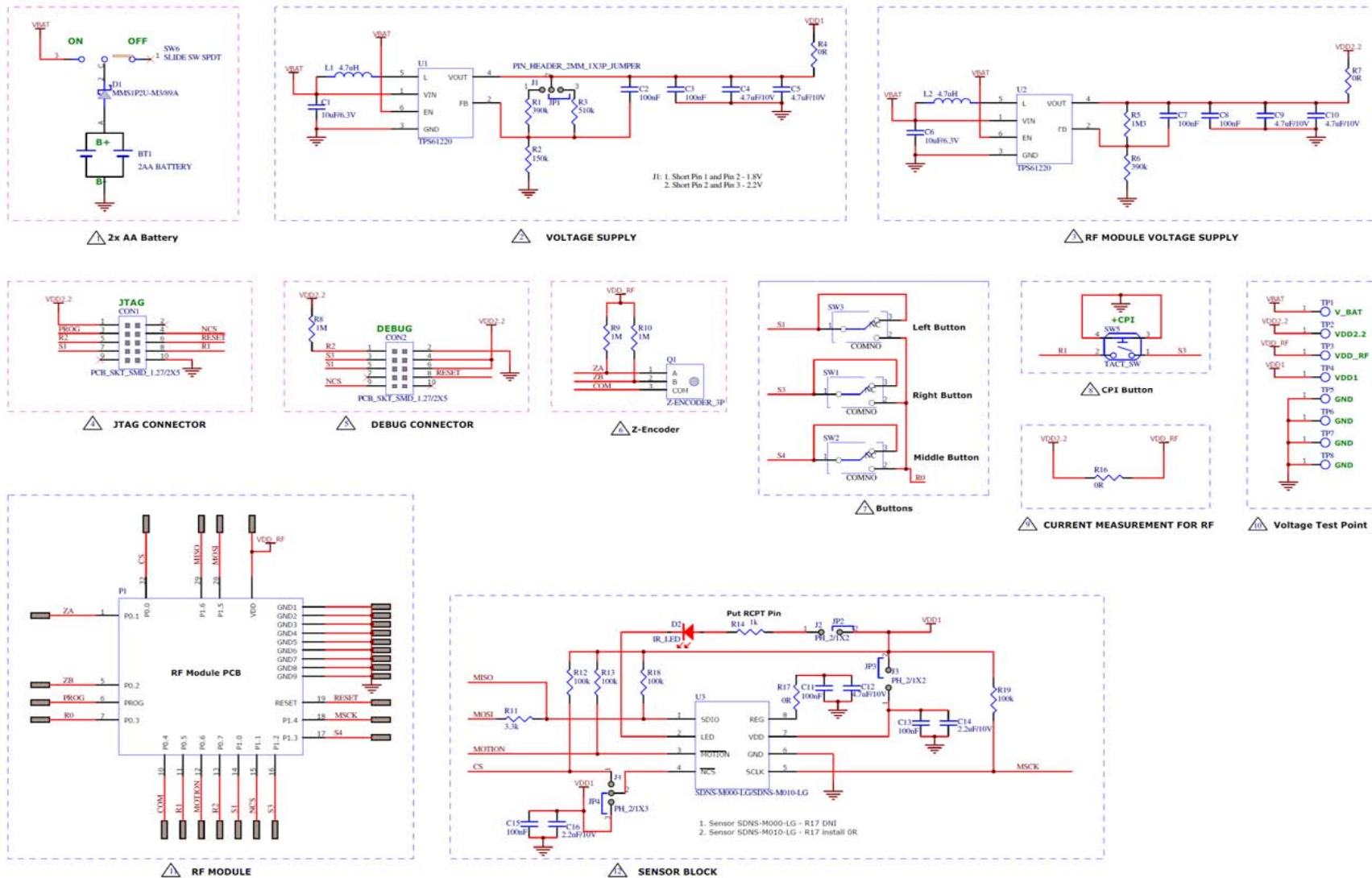

Figure 9. Schematic diagram for interface between PMW3320DB-TYDU and microcontroller with HSDL-4261 IR LED on a cordless solution

Design Considerations for Improved ESD Performance

For improved electrostatic discharge performance, typical creepage and clearance distance are shown in the table below. Assumption: base plate construction is as per the PixArt Imaging supplied IGES file and LM31-LNG lens. Note that the lens material is polycarbonate or polystyrene HH30. Therefore, cyanoacrylate based adhesives or other adhesives that may damage the lens should NOT be used.

LM31-LNG	Typical Distance (mm)
Creepage	15.43
Clearance	7.77

Regulatory Requirements

- Passes FCC B and worldwide analogous emission limits when assembled into a mouse with shielded cable and following PixArt's recommendations.
- Passes IEC-1000-4-3 radiated susceptibility level when assembled into a mouse with shielded cable and following PixArt's recommendations.
- Passes EN61000-4-4/IEC801-4 EFT tests when assembled into a mouse with shielded cable and following PixArt recommendations.
- Provides sufficient ESD creepage/clearance distance to withstand discharge up to 15KV when assembled into a mouse according to usage instructions above.

Table 2. Absolute Maximum Ratings

Stresses greater than those listed under "Absolute Maximum Ratings" may cause permanent damage to the device.

Parameter	Symbol	Min	Max	Units	Notes
Storage Temperature	T _S	-40	85	°C	
Operating Temperature	T _A	-15	55	°C	
Lead Solder Temperature	T _{SOLDER}		260	°C	For 7 seconds, 1.6mm below seating plane.
Supply Voltage	V _{DD}	-0.5	3.6	V	
ESD (Human Body Model)			2	kV	All pins
Input Voltage	V _{IN}	-0.5	V _{DD} + 0.5 V		All I/O pins

Table 3. Recommended Operating Conditions

Parameter	Symbol	Min	Typ.	Max	Units	Notes
Operating Temperature	T _A	0		40	°C	
Power Supply Voltage	V _{DD}	2.1	2.2	3.4	V	
Power Supply Rise Time	t _{RT}	0.15		20	ms	0 to V _{DD} min
Supply Noise (Sinusoidal)	V _{NA}			100	mVp-p	10kHz —50MHz
Main Oscillator Frequency	f _{OSC}		24		MHz	On-chip oscillator
Serial Port Clock Frequency	f _{SCLK}			1	MHz	50% duty cycle
Distance from Lens Reference Plane to Tracking Surface	Z	2.2	2.4	2.6	mm	
Hibernate Oscillator (Slow Clock)	f _{HIB}		580		Hz	
Speed	S		80 ^[1]		ips	Applicable only for gaming mode
Acceleration	A			20	g	In run mode
Load Capacitance	C _{out}			100	pF	SDIO

[1] Recommend placing the sensor as per Figure 2 at 0 degree to achieve optimum tracking speed.

Table 5. DC Electrical Specifications

Electrical characteristics over recommended operating conditions. Typical values at 25 °C, $V_{DD} = 2.2$ V, LED current at 16mA, white paper.

Parameter	Symbol	Min	Typ.	Max	Units	Notes
DC Supply Current (Corded Gaming Mode)	$I_{DD_RUN_CORDED}$		18.520		mA	- Including LED current.
	I_{DD_REST1}		N/A			- No load on SDIO
	I_{DD_REST2}		N/A			- For RUN mode, at typical 5300fps
	I_{DD_REST3}		N/A			
DC Supply Current (Cordless Gaming Mode)	$I_{DD_RUN_CORDLESS}$		7.894		mA	- Including LED current.
	I_{DD_REST1}		1.444			- No load on SDIO
	I_{DD_REST2}		0.090			- For RUN mode, at typical 3900fps
	I_{DD_REST3}		N/A			- For REST1 mode, at 580fps - For REST2 mode, at 10fps
DC Supply Current (Cordless Office Mode)	$I_{DD_RUN_CORDLESS}$		4.045		mA	- Including LED current.
	I_{DD_REST1}		1.355			- No load on SDIO
	I_{DD_REST2}		0.084			- For RUN mode, at typical 1500fps
	I_{DD_REST3}		0.066			- For REST1 mode, at 100fps - For REST2 mode, at 10fps - For REST3 mode, at 2fps
Power Down Current	I_{PD}		15		μ A	
Input Low Voltage	V_{IL}			$0.3 \times V_{DD}$	V	SCLK, SDIO, NCS
Input High Voltage	V_{IH}	$0.7 \times V_{DD}$			V	SCLK, SDIO, NCS
Input Hysteresis	V_{I_HYS}		100		mV	SCLK, SDIO, NCS
Input Leakage Current	I_{leak}		± 1	± 10	μ A	$V_{in} = V_{DD} - 0.6V$, SCLK, SDIO, NCS
Output Low Voltage	V_{OL}			0.45	V	$I_{out} = 1mA$, SDIO, MOTION
Output High Voltage	V_{OH}	$V_{DD} - 0.45$			V	$I_{out} = -1mA$, SDIO, MOTION
Input Capacitance	C_{in}		50		pF	SDIO, NCS, SCLK

Registers

PMW3320DB-TYDU registers are accessible via the serial port. The registers are used to read motion data and status as well as to set the device configuration.

Address	Register Name	Register Description	Read/Write	Default Value
0x00	PROD_ID	Product ID	R	0x3b
0x01	REV_ID	Revision ID	R	0x00
0x02	MOTION	Motion Detected	R/W	0x00
0x03	DELTA_X	X Displacement	R	0x00
0x04	DELTA_Y	Y Displacement	R	0x00
0x05	SQUAL	Surface Quality	R	0x00
0x06	SHUT_HI	Shutter Open Time (Upper 5-bit)	R	0x01
0x07	SHUT_LO	Shutter Open Time (Lower 8-bit)	R	0x00
0x08	PIX_MAX	Maximum Pixel Value	R	0x00
0x09	PIX_ACCUM	Average Pixel Value	R	0x00
0x0a	PIX_MIN	Minimum Pixel Value	R	0x7f
0x0b	PIX_GRAB	Pixel Grabber	R/W	0x00
0x0c	DELTA_XY	Upper 4 Bits for Delta X & Y Displacement	R	0x00
0x0d	RESOLUTION	Resolution	R/W	0x80
0x0e	RUN_DOWNSHIFT	Downshift Time from Run to Rest 1	R/W	0x08
0x0f	REST1_PERIOD	Time Period of Rest 1	R/W	0x02
0x10	REST1_DOWNSHIFT	Downshift Time from Rest 1 to Rest 2	R/W	0x10
0x11	REST2_PERIOD	Time Period of Rest 2	R/W	0x1d
0x12	REST2_DOWNSHIFT	Downshift Time from Rest 2 to Rest 3	R/W	0x2f
0x13	REST3_PERIOD	Time Period of Rest 3	R/W	0x95
0x17	MIN_SQUAL_RUN	Min SQUAL Run	R/W	0x0f
0x1a	AXIS_CONTROL	Orientation	R/W	0x00
0x22	PERFORMANCE	Performance	R/W	0x00
0x23	LOW_MOT_JIT	Low Motion Jitter Control	R/W	0x14
0x36	SHUT_MAX_HI	Maximum Shutter Open Time (Upper 5-bit)	R/W	0x0f
0x37	SHUT_MAX_LO	Maximum Shutter Open Time (Lower 8-bit)	R/W	0x00
0x39	FRAME_RATE	Frame Rate	R/W	0x8d
0x3a	POWER_UP_RESET	Power Up Reset	W	0x00
0x3b	SHUTDOWN	Shutdown	W	0x00
0x3f	NOT_REV_ID	Inverted REV ID	R	0xff
0x40	LED_CONTROL	LED Control	R/W	0x00
0x41	MOTION_CTRL	Motion Control	R/W	0x00
0x42	BURST_READ_FIRST	Burst Read Starting Address Register	R/W	0x03
0x45	REST_MODE_STATUS	Rest Mode Status	R	0x00
0x4f	NOT_PROD_ID	Inverted Product ID	R	0xc4
0x63	BURST_MOTION	Burst Read	R	0x00